



# VDM-2 Ceramic Diaphragm Transducer

**Programmable precision vacuum pressure transducer**

Piezo diaphragm

Voltage output

RS-232/RS-485 digital interface

Relay setpoints



OPM-VDM-2-01, Revision: 1, Nov 2025



**Operating Manual**

Our passion | Your value™



## Table of contents

General information.....	3
Symbols used.....	3
Intended use.....	3
Safety information.....	3
Disposal in the European Union.....	3
Warranty.....	4
Returns.....	4
Liability.....	4
Trade Restrictions and Export Control.....	4
VDM-2 Vacuum Transducer.....	5
Labeling.....	5
About the VDM-2 Vacuum Transducer.....	6
Clean and Dry Sensor Design.....	6
Alternative to Capacitance Diaphragm Gauges.....	6
Built for Harsh Environments.....	6
Rugged and Reliable.....	6
Part Numbers.....	7
Configuration Accessories.....	8
USB-powered Converter and Programmer.....	8
Wall plug-powered USB Converter and Programmer.....	9
S4-Connect Programmer.....	9
Software for Configuration and On-screen Measurement.....	9
Calibration.....	9
Mechanical Installation.....	10
Application and Process compliance.....	10
Electrical Installation.....	10
Electrical Connection (D-sub).....	10
Electrical Connection (Hirschmann GO-6 connector).....	12
Electrical connection (RJ45/8P8C connector).....	13
Status LED.....	14
Signal-to-Pressure Conversion (0-10 VDC voltage output).....	15
Analog Output 0-10V (0-1000 Torr).....	15
Analog Output 0-10V (0-500 Torr).....	15
Analog Output 0-10V (0-1000 mbar).....	16
Analog Output 0-10V (0-500 mbar).....	16
S4-Connect™ Communication.....	17
Getting started.....	17
S4-Connect USB programmer LED signals.....	18
USB-to-Serial Converter.....	18
USB-to-Serial Converter.....	18
Digital Command Set.....	19
Device Address (ADR).....	20
Analog Output Configuration (AOUT).....	20
Programmable linear analog output (AO).....	21
Set Baud Rate (BAUD).....	22
Pressure Measurement (P).....	23
Quick Data Acquisitions (Q).....	23
Temperature Measurement (T).....	23
Unit (U).....	24
Statistics (STAT).....	24
Switch Function (Optional).....	26
Configuration of Setpoint.....	27
Pre-configuration of Setpoint values.....	28
Product Information and Identification.....	29
Serial number.....	29
Part number.....	29
Manufacturer identity.....	29
Firmware version.....	29
Maintenance.....	29
Adjustment of the Zero Offset Point.....	29
Adjustment of Full-scale.....	30
Resetting to factory default.....	31
900 Series Vacuum Transducer Compatibility.....	33
Return.....	34
RMA – Return Material Authorization.....	35
Specifications.....	36

---

Dimensions .....	37
Accessories .....	38
Declaration of Conformity .....	39
Contact and support.....	40

## General information

Thank you for purchasing this Sens4 product. This operating manual contains important safety information, and we encourage you to read this manual and the quick start guide prior to installation and use of this product.

## Symbols used

The following symbols are used in this manual:



**WARNING!** Critical information to prevent dangerous situations that can result in serious injury or death.



**CAUTION!** Important information to prevent dangerous situations that can damage the device or auxiliary equipment.



**ACTION!** Requires action or attention.



**INFORMATION:** Important recommendations and information for efficient use and best practice.

## Intended use

The VDM-2 vacuum transducer is intended for vacuum gas pressure measurement and control within the limits listed in the specifications on page 36. The device is designed for KF fittings or screw-in fittings mounting.

The device complies with EMC (Electro Magnetic Compatibility) class B immunity requirements for industrial environments.

## Safety information

This product should be installed and operated by technically skilled or trained personnel only.



**WARNING!** This product is not intended for installation and use in the presence of flammable gases or other explosive environments.



**WARNING!** Ensure that the gases or liquids exposed to the wetted materials are compatible with the wetted materials described in the specifications table and the used sealing materials.



**WARNING!** The pressure rating of the sensor elements, connecting process fittings and sealing must comply with the maximum possible pressure in the application.

The CE marking on the device does not apply to the pressure equipment directive (PED) (2014/68/EU).



**WARNING!** Ensure that the process connection is tightened according to the recommended torque specification. Ensure that there are no leaks from the process connection before pressurizing the installation.



**WARNING!** Do not remove the transducer from the installation when the installation is evacuated, pressurized or contains hazardous fluids.

## Disposal in the European Union

At the end-of-life of this product, it must be disposed according to the European Directive 2012/19/EU (WEEE). This product should not be mixed with general household waste.



**WARNING!** Ensure proper decontamination of the product before disposal if it has been exposed to humanly or environmentally hazardous materials during its use.



For proper treatment, recovery and recycling, please take this product to designated collection points. Please contact your local authority for further details of your nearest designated collection point.

---

## Warranty

Sens4 warrants this product under normal use and service to be free from defects in materials and workmanship for a period of twenty-four (24) months from the date of the delivery.

Warranty does not cover mechanical damage, corrosive damage, physical contamination, deposition contamination, damage caused by shipping, normal wear and tear, incorrect use, misuse, incorrect installation or operation beyond the published design limits and specifications.

In case of warranty claim the customer should notify Sens4 immediately and no later than 3 weeks after the defect has been discovered. The warranty claim must specify the failure mode and other relevant information about the product defect and the application use. Sens4 can request return of a failed product for examination and root cause analysis that arises from a warranty claim. Sens4 will at its discretion credit, repair or replace the failed products that are accepted to be covered by warranty.

Warranty is void, regardless of the root cause of defect, if a product has been exposed to or contaminated with radioactive, chemical, biological or other harmful or dangerous substances.

Warranty does not apply to products that have been hardware modified, altered or dismantled by the customer or third party.

Software provided by Sens4 is supplied "as is" without warranty of any kind or guaranteed compatibility with customer IT systems and environment.

## Returns

All returns to Sens4 must be authorized by Sens4 by issuing an RMA (Returned Material Authorization) prior to shipping. Contact Sens4 support to obtain an RMA number and fill out the form on page 35.

Sens4 will not accept return of products that have been exposed to or contaminated with radioactive, chemical, biological or any other harmful or dangerous substances.

Return of unpacked and unused products for credit requires written acceptance from Sens4 and will be subject to a handling fee.

## Liability

The customer is solely responsible for determining the suitability and compatibility of the product for the customers application, environment and intended use. Sens4 is not liable for any claims arising from improper use, incorrect installation or use with gases or liquid not compatible with the media wetted materials described in the specifications table. To the extent permitted by law, Sens4 is not liable for incidental and consequential damages, including but not limited to loss of profits or revenue, overheads, loss of data, reinstallation costs, damage to other equipment or any incidental or consequential damages of any nature.

Sens4 has taken reasonable care to ensure that the content of its published information and specifications is accurate and up-to date. However, Sens4 does not guarantee or warrant that the content of the published information is error-free. Sens4 reserves the right to change its product specifications without prior notice.

## Trade Restrictions and Export Control

**In the event that the product is exported, transferred or in any way distributed to another country or territory than delivered to by Sens4, the recipient and/or customer is responsible for compliance to export restrictions, regulations or applicable law of Denmark, local law and/or the law of the European Union.**

**Diversion or transfer contrary to law of Denmark and/or law of the European Union is prohibited.**

**For export compliance questions consult your local authorities and/or Sens4 on email: [info@sens4.com](mailto:info@sens4.com)**

## VDM-2 Vacuum Transducer

The VDM-2 is available with different electrical connections and vacuum fittings. The illustration below is an example of the VDM-2 with D-sub connector and DN16KF vacuum fitting.

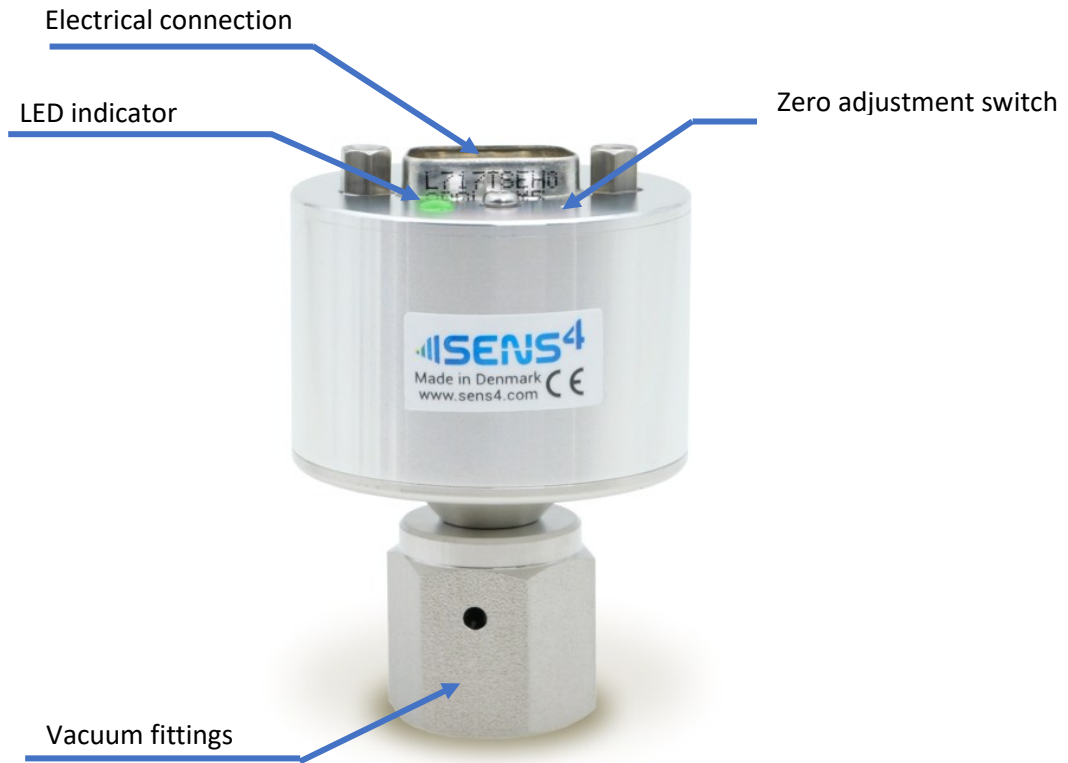

## Labeling

If the serial label should become unreadable, the serial- and part numbers are also stored in the internal non-volatile memory and can be read using the S4-Connect™ USB programmer and communicator. See page 27.

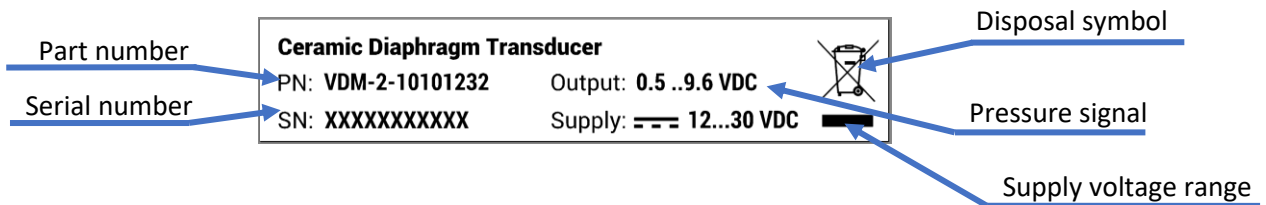

## About the VDM-2 Vacuum Transducer

The VDM-2 Ceramic Diaphragm vacuum transducer is based on a corrosion resistant aluminum oxide diaphragm that bends as function of the applied pressure. The core pressure sensor element utilizes piezo resistive measurement. The diaphragm sensor measures the vacuum gas pressure independently of gas type or composition.

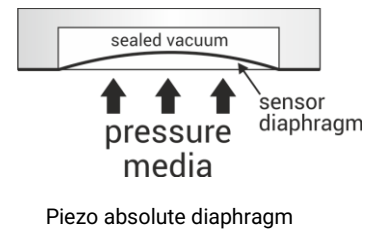

The VDM-2 Ceramic Diaphragm vacuum transducer is based on a corrosion resistant aluminum oxide diaphragm that bends as function of the applied pressure. The core pressure sensor element utilizes piezo resistive measurement. The diaphragm sensor measures the vacuum gas pressure independently of gas type or composition.

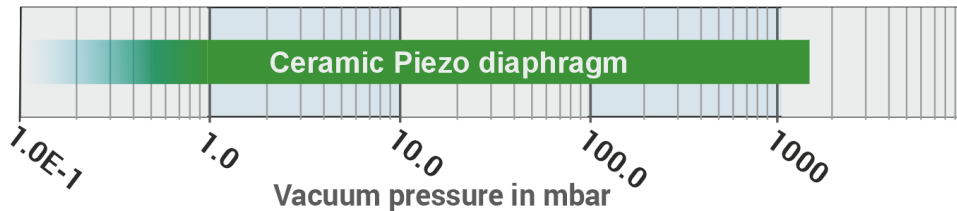

## Clean and Dry Sensor Design

Unlike stainless steel Piezo vacuum transducers that rely on oil-filled sensor elements, the Ceramic Piezo sensor element in the VDM-2 is completely clean and dry—eliminating any risk of contaminating the vacuum system.

## Alternative to Capacitance Diaphragm Gauges

Capacitance Diaphragm Gauges (CDGs) are commonly used for precise measurement and control in advanced vacuum processes. The VDM-2 provides a compact and cost-effective alternative to traditional CDGs with full-scale ranges up to 1000 Torr/mbar.

## Built for Harsh Environments

Designed for demanding vacuum applications, the VDM-2 operates reliably in the presence of corrosive gases and chemical compounds. Its ceramic aluminum oxide diaphragm delivers excellent resistance to solvents and acids.

An optional Parylene protective coating further enhances corrosion and oxidation resistance. Parylene—a unique, hydrophobic polymer—was originally developed for medical processes such as lyophilization and hydroperoxide plasma sterilization.

For systems containing macroscopic particulates, an optional protective baffle effectively prevents contaminant deposition on the sensor diaphragm.

## Rugged and Reliable

The aluminum oxide sensor element is exceptionally durable, withstanding rapid venting and overpressure up to 2 bar absolute (29 psia).

## Part Numbers

The VDM-2 is available with different electrical connections and process fittings.

VDM-2-	1	0	1	0	1	2	3	2	
<b>Vacuum flange / sensor protection</b>									<b>Connection</b>
DN16KF	1	0							1 9 Pin D-sub male
DN25KF	2	0							2 15 pin HD D-sub male
NPT 1/8"	3	0							3 15 pin HD D-Sub male / dual analog out
VCR4 female	4	0							7 8 pin RJ45 / FCC68, ID Res 27K
VCR8 female	5	0							8 8 pin RJ45 / FCC68, ID Res 36K
DN16CF rotatable	6	0							D 6 pin Hirschmann, ID res 13K9
DN16KF Extended	8	0							
DN16KF with light baffle	1	1							<b>Setpoints</b>
DN16KF with heavy duty baffle	1	2							0 None
DN25KF with light baffle	2	1							1 1x Solid-State Relay (Only 9 pin D-sub)
DN25KF with heavy duty baffle	2	2							2 2x Solid State Relays (Only RJ45/FCC68)
DN16KF, Parylene protected sensors	1	6							3 3x Solid State Relays (Only 15 pin HD D-sub)
DN25KF, Parylene protected sensors	2	6							<b>Unit</b>
NPT 1/8", Parylene protected sensors	3	6							1 torr
VCR4 female, Parylene protected sensors	4	6							2 mbar
VCR8 female, Parylene protected sensors	5	6							3 Pascal
DN16CF rotatable Parylene protected sensors	6	6							
DN16KF Extended, Parylene protected sensors	8	6							
DN16KF with light baffle, Parylene	1	7							
DN25KF with light baffle, Parylene	2	7							
<b>Digital interface</b>									
RS-232 / S4-Connect™ (9 and 15 pin D-sub)			1						
RS-485 / S4-Connect™ (9 and 15 pin D-sub)			2						
S4-Connect™ (RJ45/FCC68 and Hirschmann)			3						
<b>Analog Output</b>									
0.5 - 9.5 1 V/dec (Sens4 VPM-5,7,15,17..)			0		1				
1.0-9 VDC 1 VDC/Dec (MKS 901P/925/910)			0		2				
0-10 VDC 100 Torr linear Capacitance manometer			1		3				
0-10 VDC 1000 Torr linear (MKS 902B)			1		4				
0-10 VDC 500 Torr FS linear			3		7				
0-10 VDC 200 Torr FS linear			3		8				
1-9.8 VDC (Pfeiffer APR 250, 260... 1000 mbar)			3		9				
1-9.8 VDC (Pfeiffer APR 250, 260... 2000 mbar)			4		0				
0-5V VDC 1000 Torr FS linear (MKS 902B)			4		2				
0-5V VDC 10 Torr FS linear			4		3				
0-10VDC 100 mbar FS Capacitance manometer			5		7				
0-10VDC 200 mbar FS Capacitance manometer			5		8				
0-10VDC 500 mbar FS Capacitance manometer			5		9				
0-10VDC 1000 mbar Capacitance manometer			6		0				
0-10VDC 1100 mbar Capacitance manometer			6		1				

## Configuration Accessories

When configuring the various digital and analog parameters of the VDM-2, three different categories of connectors can be used – as described in the following sections.

Neither of these connectors are included with the transducer and must be purchased separately.

### USB-powered Converter and Programmer

The USB-powered converter and programmer provides direct USB communication and power from the PC.

The USB-powered programmer is compatible with VDM-2 transducers.



Part number	Description
PRG-RS2-DS15-UP	RS-232 USB programmer, 1.5 m cable, D-sub 15 pin, USB powered
PRG-RS4-DS15-UP	RS-485 USB programmer, 1.5 m cable, D-sub 15 pin, USB powered
PRG-RS2-DS9-UP	RS-232 USB programmer, 1.5 m cable, D-sub 9 pin, USB powered
PRG-RS4-DS9-UP	RS-485 USB programmer, 1.5 m cable, D-sub 9 pin, USB powered

## Wall plug-powered USB Converter and Programmer

The wall plug-powered variant includes either a USB-to-RS-232 or USB-to-RS-485 converter along with a 90-230 VAC wall plug power supply that enables powering of the transducer independently of a PC.

The wall plug power supply is compatible with VDM-2 transducers and MKS 901P, 902B, 910, 925, 971B, 972B and 974B.



Part number	Description
PRG-RS2-DS15-WP	RS-232 USB programmer, 1.5 m cable, D-sub 15 pin, wall plug-powered
PRG-RS4-DS15-WP	RS-485 USB programmer, 1.5 m cable, D-sub 15 pin, wall plug-powered
PRG-RS2-DS9-WP	RS-232 USB programmer, 1.5 m cable, D-sub 9 pin, wall plug-powered
PRG-RS4-DS9-WP	RS-485 USB programmer, 1.5 m cable, D-sub 9 pin, wall plug-powered

## S4-Connect Programmer

The S4-Connect communicates digitally via the power supply line, enabling configuration of products that would otherwise not have a standard digital interface like RS-232 or RS-485.



S4-Connect is available in four configurations:

Part number	Description
PRG-S4-RJ45	S4-Connect™ USB programmer, 1.5 m cable, RJ45, 8-pin
PRG-S4-HIR6	S4-Connect™ USB programmer, 1.5 m cable, Hirschmann GO-6, 6-pin

## Software for Configuration and On-screen Measurement

The S4-Connect™ and RS-232/485 software is freeware and can be downloaded from the Sens4 website: <https://sens4.com/support/>

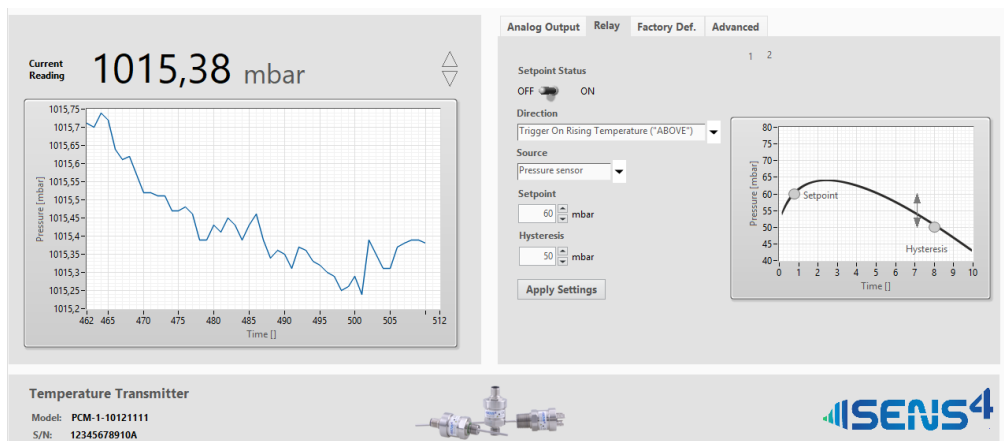

## Calibration

The VDM-2 is delivered factory-calibrated with a calibration test report. An optional accredited calibration traceable to national standards can also be supplied with the VDM-2 transducer.



**INFORMATION:** The VDM-2 should be zero adjusted after first time installation. Zero offset on measurement can shift during transportation or if the mounting orientation is changed.

## Mechanical Installation

The VDM-2 transducer is available with KF clamp fittings or screw-in fittings.



**CAUTION!** For screw-in fittings do not exceed tightening torque values.



**CAUTION!** Use gloves when handling vacuum fittings. Ensure that the O-ring and vacuum sealing surfaces are clean and free of scratches or other damages.

The VDM-2 transducer can be mounted horizontally or vertically without impact on accuracy or performance.

## Application and Process compliance

The VDM-2 transducer is intended for use in vacuum applications where the exposed media is compatible with ceramic, Viton and stainless steel.

## Electrical Installation

The VDM-2 requires an external power supply supplying in the range 12-30 VDC. The external power supply shall be with safe isolation according to PELV (Protective Extra Low Voltage) requirements of EN60204-1.

The transducer is protected against momentary overvoltage on the supply line. The internal 100 mA thermal fuse will limit current draw in case of overvoltage to limit overheating.

Additionally, the transducer is protected against reverse polarity caused by incorrect wiring to the power supply.

The transducer electronics have a high level of immunity against external electromagnetic interference.

## Electrical Connection (D-sub)

The voltage output version provides a voltage signal proportional to the measured pressure.

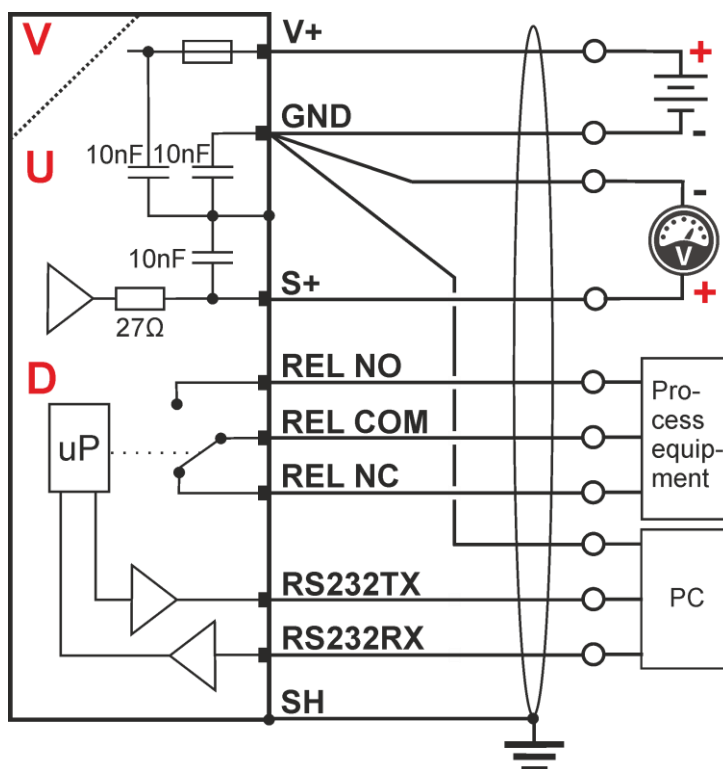

The high resolution 16-bit voltage signal can be interfaced to a PLC, A/D converter, voltmeter or other readout devices.



**INFORMATION:** It is recommended to use a differential input to measure the output signal that uses a separate signal return wire connected to the transducer connector. If power supply return and signal return share the same wire connection the voltage drop as function of supply current will cause a measurement deviation. In that case, the measurement deviation will increase with the cable length.

## Connector Pinout and Cable Wiring (0-10 VDC voltage output)

### 15-pin HD D-sub Connector

Pin	Symbol	Description
1	RS232TX	RS-232 Transmit / RS-485 (-)
2	RS232RX	RS-232 Receive / RS-485 (+)
3	V+	Supply voltage 12-30 VDC
4	GND	Supply voltage - (return)
5	S+	Analog voltage signal +
6	GND	Analog voltage signal - (return)
7	REL NO	Relay 1 NO (normally open contact) <sup>(1)</sup>
8	REL COM	Relay 1 Common <sup>(1)</sup>
9	REL NC	Relay 1 NC (normally closed contact) <sup>(1)</sup>
10	REL NC	Relay 2 NC (normally closed contact) <sup>(1)</sup>
11	REL COM	Relay 2 Common <sup>(1)</sup>
12	REL NO	Relay 2 NO (normally open contact) <sup>(1)</sup>
13	REL NC	Relay 3 NC (normally open contact) <sup>(1)</sup>
14	REL COM	Relay 3 Common <sup>(1)</sup>
15	REL NO	Relay 3 NO (normally open contact) <sup>(1)</sup>

(1) Optional relay

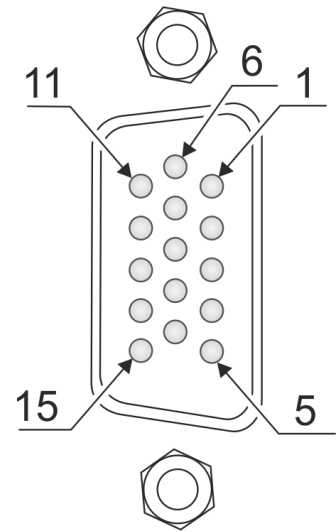

### 9-pin D-sub Connector

Pin	Symbol	Description
1	REL NO	Relay 1 NO (normally open contact) <sup>(1)</sup>
2	REL NC	Relay 1 NC (normally closed contact) <sup>(1)</sup>
3	V+	Supply voltage 12-30 VDC
4	GND	Supply voltage - (return)
5	S+	Analog voltage signal +
6	REL COM	Relay 1 Common <sup>(1)</sup>
7	RS-232TX	RS-232 Transmit / RS-485 (-)
8	GND	Analog voltage signal - (return)
9	RS-232RX	RS-232 Receive / RS-485 (+)

(1) Optional relay

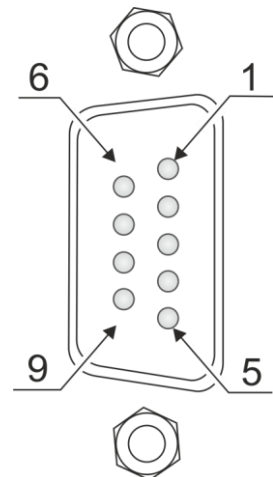

## Electrical Connection (Hirschmann GO-6 connector)

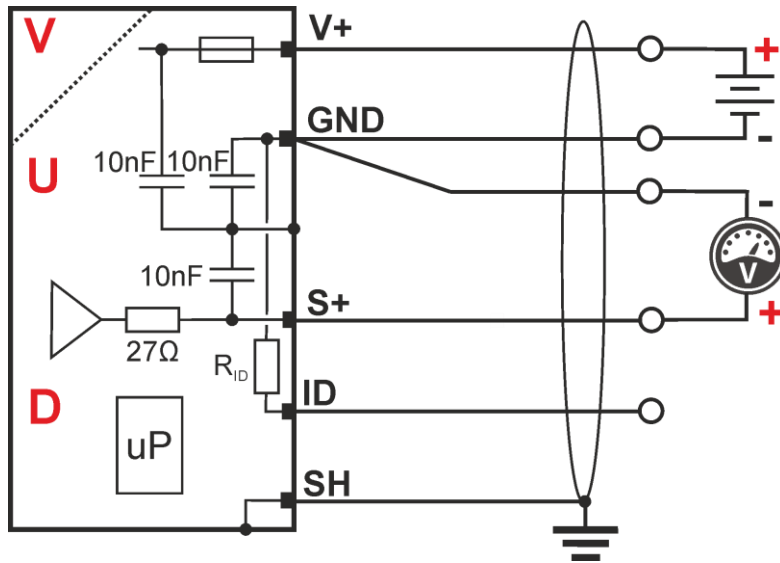

### 6-pin Hirschmann GO-6 connector

Pin	Symbol	Description
1	ID	Identification resistor (3K)
2	S+	Analog voltage signal +
3	GND	Analog voltage signal - (return)
4	V+	Supply voltage 12-30 VDC
5	GND	Supply voltage - (return)
6	CH	Chassis

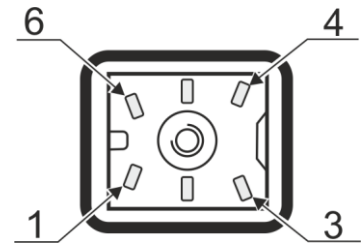

**INFORMATION:** It is recommended to use a differential input to measure the output signal that uses a separate signal return wire connected to the transducer connector. If power supply return and signal return share the same wire connection the voltage drop as function of supply current will cause a measurement deviation. In that case, the measurement deviation will increase with the cable length.

## Electrical connection (RJ45/8P8C connector)

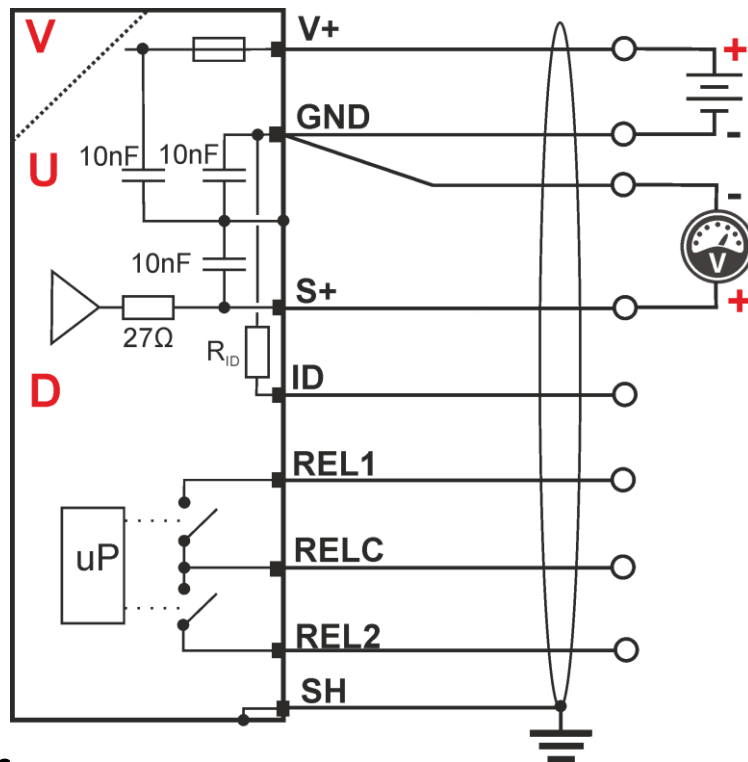

### RJ45/8P8C connector

Pin	Symbol	Description
1	V+	Supply voltage 12-30 VDC
2	GND	Supply voltage - (return)
3	S+	Analog pressure voltage signal +
4	ID	Identification resistor <sup>(7)</sup>
5	GND	Analog voltage signal - (return)
6	REL2	Relay 2 Setpoint (closing contact)
7	REL1	Relay 1 Setpoint (closing contact)
8	RELC	Relay 1 and 2 common

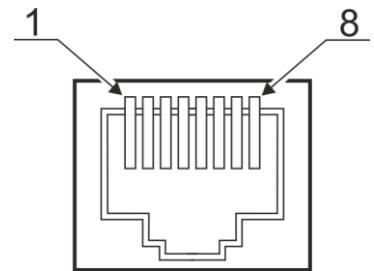

(7) Identification resistor for RJ45/8P8C connector

The identification resistor is used by external equipment to identify the type of transducer. External equipment can be a display or a controller from another vendor. The VDM-2 is available with different ID resistors. The ID resistor is identified by the last digit in the part number:

P/N	ID resistor value
5	27 KΩ
6	36 KΩ
7	43 KΩ



**INFORMATION:** It is recommended to use a differential input to measure the output signal that uses a separate signal return wire connected to the transducer connector. If power supply return and signal return share the same wire connection the voltage drop as function of supply current will cause a measurement deviation. In that case, the measurement deviation will increase with the cable length.

---

## Status LED

The LED indicator signals the transducer status and can indicate following basic indications:

### Startup sequence

- 0.5 sec purple followed by 4 sec. pulsing green

### Normal standard operation

- Solid green

### Overrange indication (in Dynamic Mode only)

- Flashing Orange (5 Hz)

### S4-Connect mode

- Pulsing green

### Sensor fail stage

- Flashing red (5 Hz)



## RGB LED for pressure indication (Dynamic mode)

The VDM-2 introduces a new approach for visually determining the measured pressure by a multi-color LED that smoothly changes color throughout the pressure range. This selectable visual function is a low-cost alternative to integrated displays and provides a rough visual indication of the measured pressure.

When the VDM-2 measures a pressure that exceeds its maximum measuring range of 1333 mbar (1000 Torr) the LED will blink orange.

The dynamic LED can be enabled via the digital interface. Refer to page for LED configuration.

### Signal-to-Pressure Conversion (0-10 VDC voltage output)

The transducer can provide a voltage output from 0-10 VDC and is available with different types of pre-configured output scaling.

#### Analog Output 0-10V (0-1000 Torr)

The voltage signal  $u$  can be converted to pressure using the following linear expression:

Voltage to pressure conversion (torr):  $P(u) = \left(\frac{u}{10}\right) \times 1000$

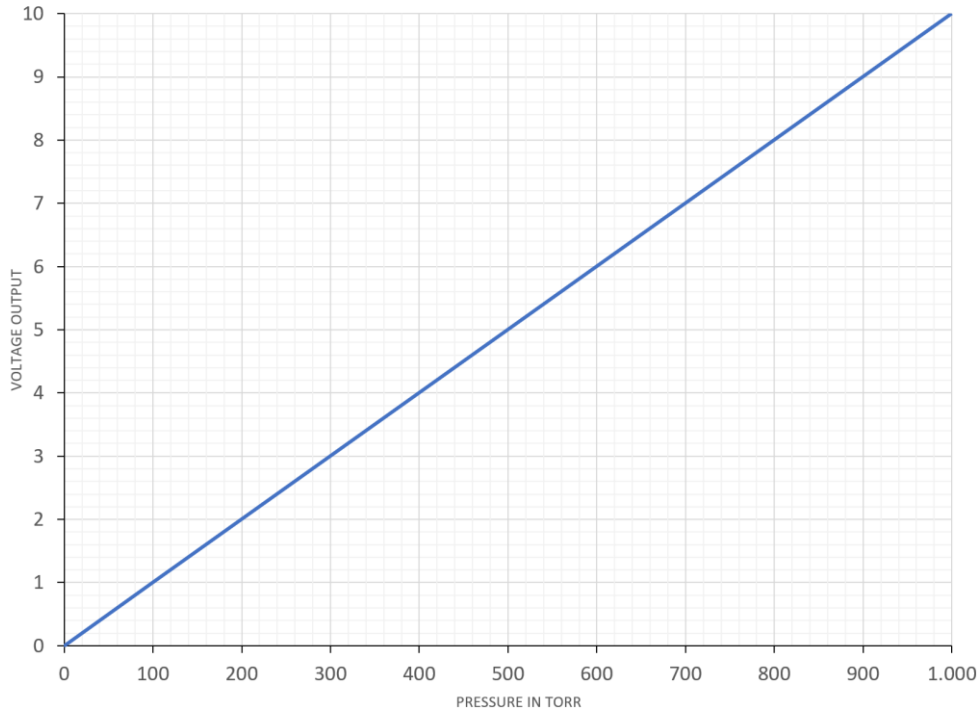

#### Analog Output 0-10V (0-500 Torr)

The voltage signal  $u$  can be converted to pressure using the following linear expression:

Voltage to pressure conversion (torr):  $P(u) = \left(\frac{u}{10}\right) \times 500$

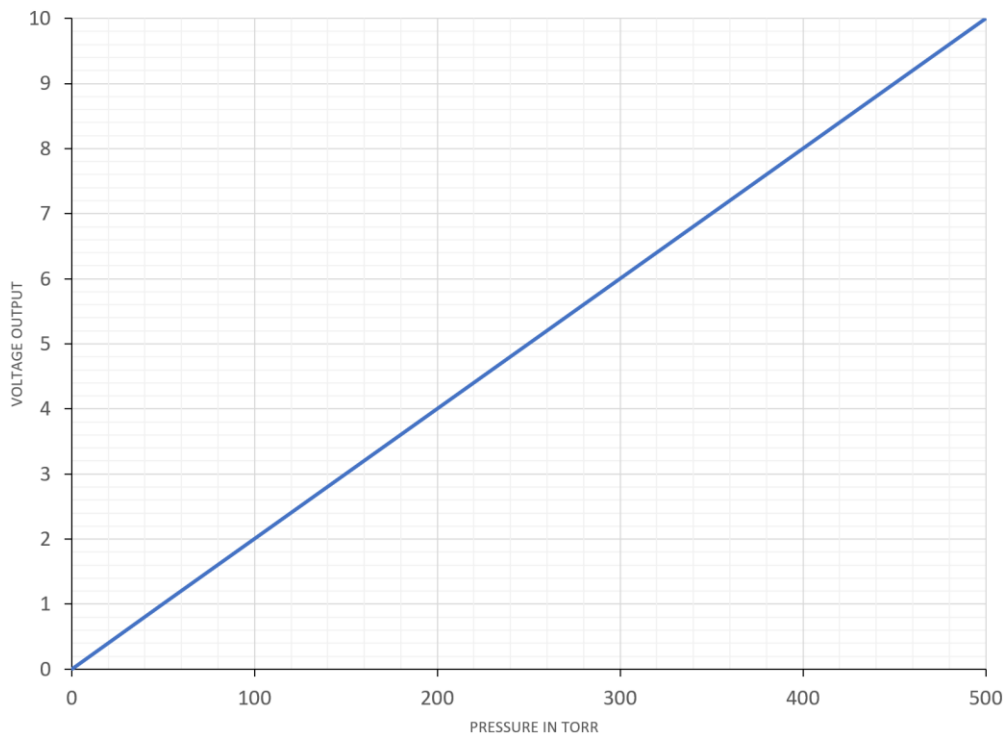

### Analog Output 0-10V (0-1000 mbar)

The voltage signal  $u$  can be converted to pressure using the following linear expression:

$$\text{Voltage to pressure conversion (mbar): } P(u) = \left(\frac{u}{10}\right) \times 1000$$

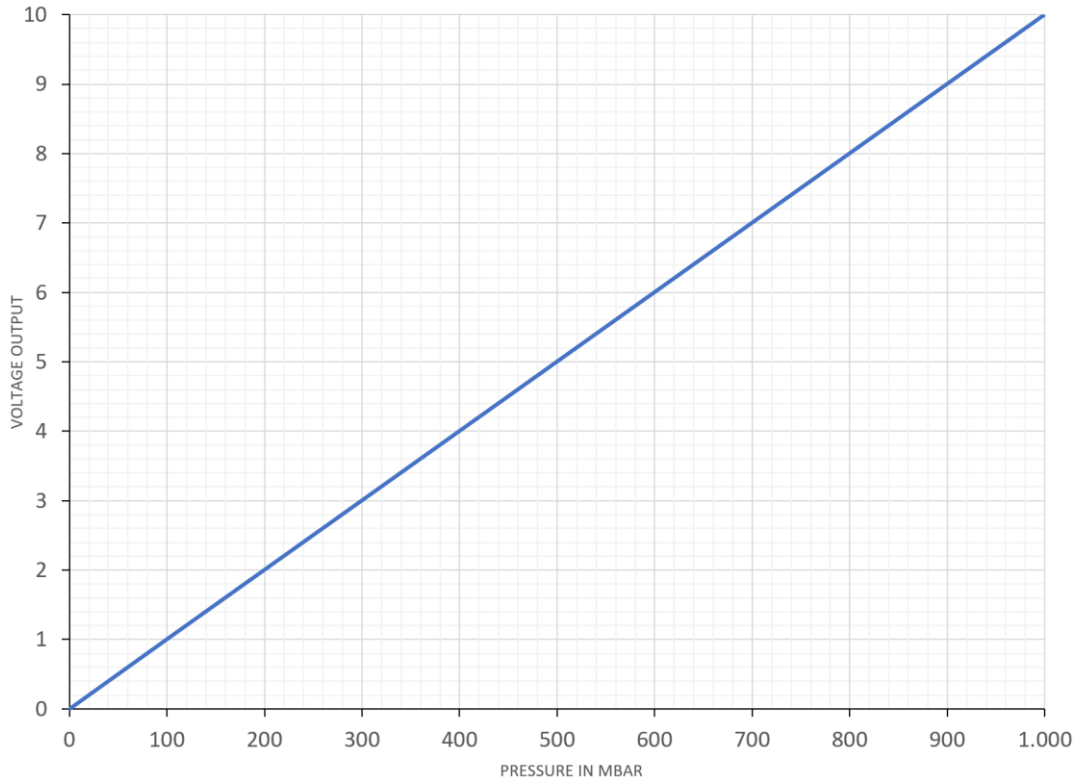

### Analog Output 0-10V (0-500 mbar)

The voltage signal  $u$  can be converted to pressure using the following linear expression:

$$\text{Voltage to pressure conversion (mbar): } P(u) = \left(\frac{u}{10}\right) \times 500$$

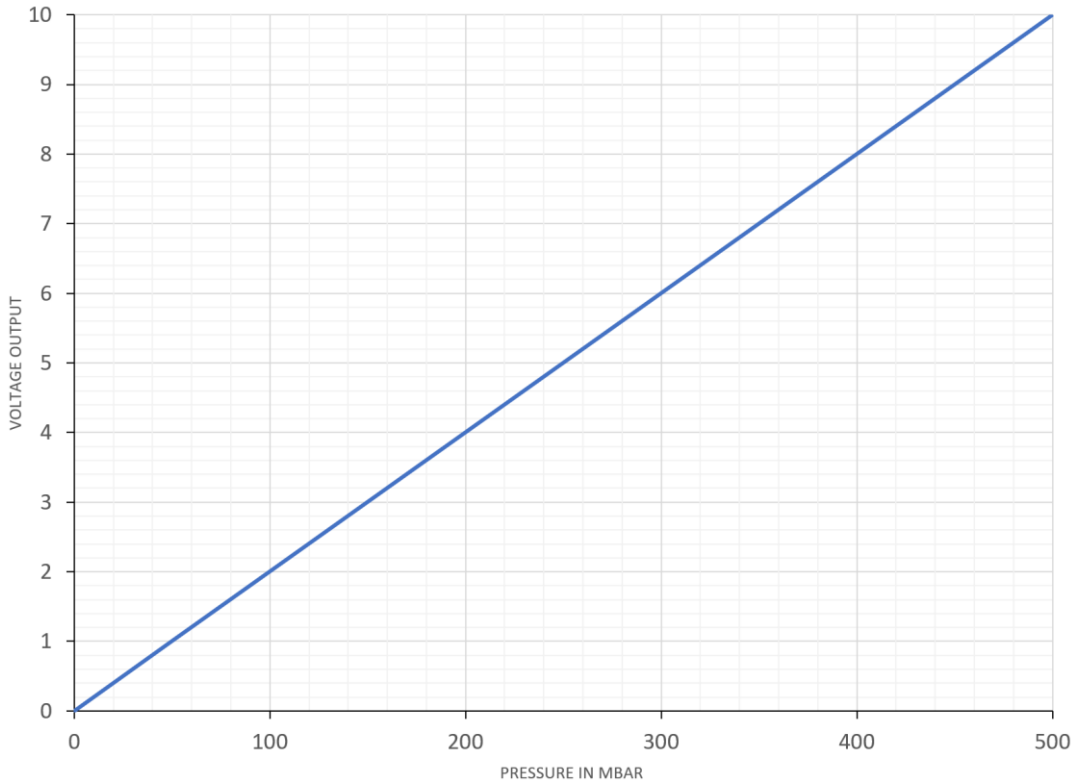

## S4-Connect™ Communication



The S4-Connect™ USB programmer and communicator provides access from PC software via a USB interface to the digital core of the transducer. It is compatible with both 4-20 mA current output and 0-10 VDC voltage output transducers from Sens4.



It is intended for configuration, calibration and setup of the unit, but it can also be used to acquire measurement data and perform diagnostics using a PC.

The S4-Connect™ interface enables easy and cost-optimized access to perform calibration, adjustments and individual configuration of the transducer product to fit the customer application and requirements.

During the power-up cycle the transducer will detect if there is a S4-Connect™ programmer connected and if so, the transducer will enter the S4-Connect™ service mode.



**WARNING!** The S4-Connect™ interface is not intended for digital communication between process equipment and the VDM-2 transducer unit. Disconnect the transducer from any external installation before enabling the S4-Connect™ service mode. During the S4-Connect™ service mode the analog voltage output or analog current output will be disabled, and the analog output will be used for digital communication between transducer and S4-Connect™ programmer.

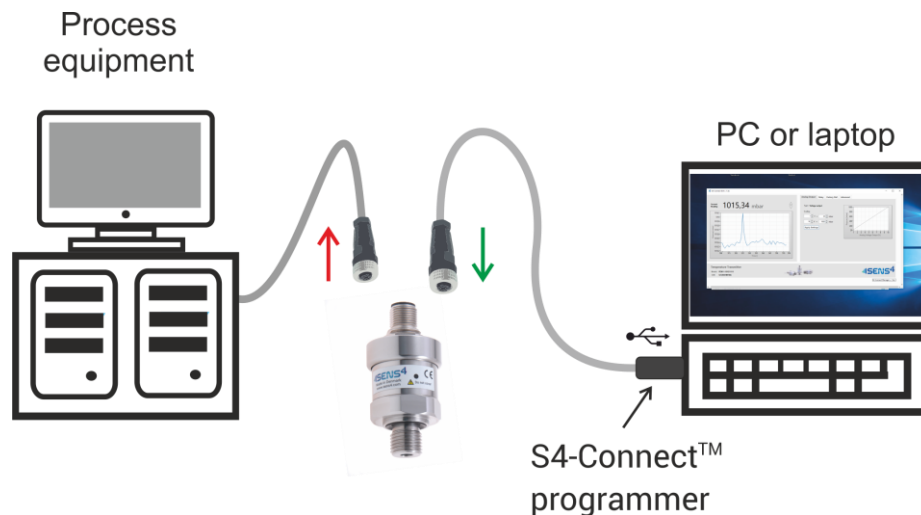

### Getting started:

1. Remove the electronics connection to the transducer so that it is disconnected from any process equipment.
2. Download the S4-Connect™ software from [www.sens4.com](http://www.sens4.com) and install the software. Alternatively, a standard serial terminal software can be used.
3. Connect the programmer to the PC and the S4-Connect™ software. The S4-Connect™ programmer will then enter a state where it searches for the transducer. During this period the LED on the programmer will alternate between green and blue.
4. Connect the transducer to the S4-Connect™ cable. The S4-Connect™ programmer's LED will turn solid green if a current output transducer is connected and solid blue if a voltage output transducer is connected.
5. When the S4-Connect™ programmer's LED turns solid blue or green, it's ready for communication.

## S4-Connect USB programmer LED signals

The S4-Connect™ USB programmer has an LED indicator that provides the following signals:

- ● Alternating blue/green: Searching for transducer.
- Solid blue: Voltage output transducer connected.
- Solid green: Current output transducer connected.
- White strobe: Locate mode for S4-Connect™ programmer (see page 20).

## USB-to-Serial Converter

The USB-to-Serial Converter is the quickest and simplest way to provide connectivity between an RS-232 or RS-485 capable Sens4 transducer and a computer or other compatible device.

Featuring a built-in switch-mode power supply, the converter eliminates the need for an external power supply.



## USB-to-Serial Converter

The USB-to-Serial Converter is the quickest and simplest way to provide connectivity between an RS-232 or RS-485 capable Sens4 transducer and a computer or other compatible device. The USB-to-Serial Converter is the preferred device for continuously acquiring of measurement data at high communication speed.

Featuring a built-in switch-mode power supply, the converter eliminates the need for an external power supply.



## Digital Command Set

The VDM-2 is available with S4-Connect and either an RS-232 or an RS-485 serial interface. Communication is based on an ASCII protocol that includes a start character, device address, command or query and an end character for termination:

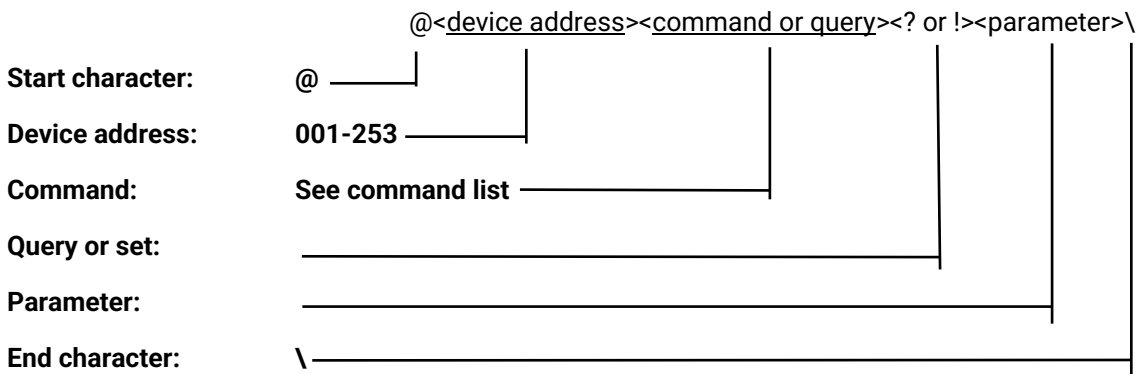

**INFORMATION:** Throughout this manual the signs <> are written for separation of command name and values and are for informational purposes only. These signs should not be entered in the actual command

### Example of how to send a command to the transducer

Programming the Setpoint 1 value to 1.23E-4 (using the default unit setting of the transducer, i.e. mbar):

Send:            @254SPV!1,1.24E-4\  
 Reply:           @ACK1.23E-4\  
 \

The following table lists all commands supported by VDM-2. Each command is described in more detail below the table.

Command	Description	Query	Set	Valid input parameter
ADR	Device address	•	•	1-3 digits (range 001-253)
AOUT	Analog output configuration	•	•	<STD / 0-39>
BAUD	Set baud rate	•	•	<4800 / 9600 / 19200 / 38400 / 57600 / 115200 / 230400> (default 9600)
FAIL	Sensor failure handling	•	•	<WORKING / ZERO >
FD	Factory default	•	•	<ADR / AO / BAUD / FS / SP / U / (NONE)>
FS	Piezo full-scale adjustment	•	•	<PRESSURE VALUE / CLEAR>
FV	Firmware version	•	-	
FVD	Firmware compile time-stamp	•	-	
MF	Manufacturer	•	-	
MD	Model name	•	-	
P	Pressure measurement	•	-	
PN	Part number	•	-	
Q	Quick query	•	•	<PARAMETER 1>, <PAR. 2> ... <PAR. 5>
SN	Serial number	•	-	
SP	Setpoint settings	•	-	
SPD	Setpoint direction <sup>(1)</sup>	•	•	<SETPOINT #>, <ABOVE / BELOW>
SPE	Setpoint enable <sup>(1)</sup>	•	•	<SETPOINT #>, <OFF / ON>
SPH	Setpoint hysteresis <sup>(1)</sup>	•	•	<SETPOINT #>, <PRESSURE VALUE>
SPV	Setpoint value <sup>(1)</sup>	•	•	<SETPOINT #>, <PRESSURE VALUE>
SPR	Setpoint relay status <sup>(1)</sup>	•	-	<SETPOINT #>
SPS	Setpoint source <sup>(1)</sup>	•	•	<SETPOINT #>, <P / T>
STAT	Statistics	•	•	<P / T / (NONE) / CLEAR (Set only)>
T	Sensor temperature	•	-	<CP / PZV / (NONE)>
U	Pressure/Temperature Measuring Unit	•	•	<P>, <MBAR / PASCAL / TORR> or

			<T>, <CELSIUS / FAHRENHEIT / KELVIN>
UT	User Tag	•	<USER TAG>
VAC	Zero adjustment	• •	<(NONE) / PRESSURE VALUE>

General note: all valid input parameters written in *italics* are to be entered as a number. These numbers will vary with the type and model number of the transducer. Refer to the specific commands for details.

- (1) Setpoint solid-state relays are optional and are not relevant for all part numbers.

## Device Address (ADR)

The VDM-2 has an addressable communication protocol, and so it will only accept commands or queries with the following addresses. All queries or commands sent to all other addresses are simply ignored.

<device address>	Pre-configured to 253, this value may be changed at any time to anything in the range 1-253 using the ADR command.
254	This is the "global" address. The VDM-2 will always respond to commands or queries at address 254, regardless of the device address setting.
255	This is the broadcast address, which may be used for performing the same operation on multiple VDM-2s at once. The VDM-2 will not issue any replies to broadcast commands. Note that broadcasting requires a multidrop communication interface such as RS-485.

Example: Change the device address from 253 (default) to 123 using the global address:

Send:            **@254ADR!123\**

Reply:           **@253ACK123\**

All replies after this one will begin with the new device address, 123.

## Analog Output Configuration (AOUT)

VDM-2's default analog output is 0.5-9.5 V, 1V/decade, however, the analog output can be configured to emulate a collection of other equipment via the AOUT command:

	Vendor or Type	Transducer model	Output
STD	Sens4	VPM-4, 5, 7, 15, 17	1 VDC/decade (0.5 – 9.5 VDC)
LINEAR	Sens4	-	Programmable linear
0	MKS	901P, 910, 925	1 VDC/decade (1-9VDC)
1	Edwards	APG-L	1.99 - 10 VDC
2	Edwards	APG-100	2.00 – 9.00 VDC
3	Edwards	WRG	2.75 – 10.00 VDC
4	Inficon Leybold	PSG500 TTR91	1.547 – 10.00 VDC
5	Inficon Pfeiffer	MPG400 PKR251	2.07 – 8.603 VDC
6	Inficon MKS	BPG400 999 Quattro	1.843 – 10.00 VDC
7	MKS Granville Phillips	275	0.372 – 5.570 VDC
8	MKS HPS	Moducell 325	0.2509 – 3.2398 VDC
9	MKS HPS	Moducell 325 x3	0.753 – 9.719 VDC
10	CDG	0.1 Torr	0 - 10.00 VDC
11	CDG	1 Torr	0 - 10.00 VDC
12	CDG	10 Torr	0 - 10.00 VDC
13	CDG	100 Torr	0 - 10.00 VDC
14	CDG	1000 Torr	0 - 10.00 VDC
15	MKS	901P piezo differential output	1 VDC/decade
16	Edwards	AIM-S / - SL	2.5 – 10.00 VDC
17	Edwards	AIM-X / XL	3.286 – 9.799 VDC
18	Pfeiffer	IKR251	2.324 – 8.500 VDC
19	Pfeiffer	TPR 265 / 280	2.199 – 8.625 VDC
20	Hastings	HPM-2002-OBE special	5.00 – 9.995 VDC

21	Edwards	DV6M	2.00 – 10.00 VDC
22	Edwards	APG-M	2.00 – 10.00 VDC
23	MKS Granville Phillips	GP275 (0-9.0 VDC)	0 – 8.80 VDC
24	Thyracont	MT 241.1	0.41 – 9.99 VDC
25	MKS Granville Phillips	(0-375.6VDC)	0.375 – 5.614 VDC
26	Edwards	APG100-LC	2.00 – 10.00 VDC
27	Edwards	APG100M	2.00 – 10.00 VDC
28	MKS	907	0.387 – 5.666 VDC
29	Alcatel	K6080	0.40 – 10.00 VDC
30	Inficon	PEG100	2.186 – 10.166 VDC
31	Varian	Esys	1.00 – 8.00 VDC
32	Alcatel	TA111	0.10 – 9.20 VDC
33	MKS	685	1.00 – 7.00 VDC
34	MKS	901P special 2VDC/decade	1.00 – 9.00 VDC
35	Pfeiffer	TTR 101	0.61 – 10.2 VDC
50	CDG	0.1 mbar full scale (linear)	0 - 10.00 VDC
51	CDG	1 mbar full scale (linear)	0 - 10.00 VDC
52	CDG	2 mbar full scale (linear)	0 - 10.00 VDC
53	CDG	5 mbar full scale (linear)	0 - 10.00 VDC
54	CDG	10 mbar full scale (linear)	0 - 10.00 VDC
55	CDG	20 mbar full scale (linear)	0 - 10.00 VDC
56	CDG	50 mbar full scale (linear)	0 - 10.00 VDC
57	CDG	100 mbar full scale (linear)	0 - 10.00 VDC
58	CDG	200 mbar full scale (linear)	0 - 10.00 VDC
59	CDG	500 mbar full scale (linear)	0 - 10.00 VDC
60	CDG	1000 mbar full scale (linear)	0 - 10.00 VDC
61	CDG	1100 mbar full scale (linear)	0 - 10.00 VDC

Example: Change the Analog output emulation to MKS Baratron 0-10VDC with 0.1 Torr full scale:

Send: @254AOUT!10\

Reply: @253ACK10\

### Programmable linear analog output (AO)

When selecting Aout to “Linear” the analog output configuration can be user configured to any linear scaling within the VDM-2 measuring range and output limitation. This feature allows magnification of a specific pressure range.

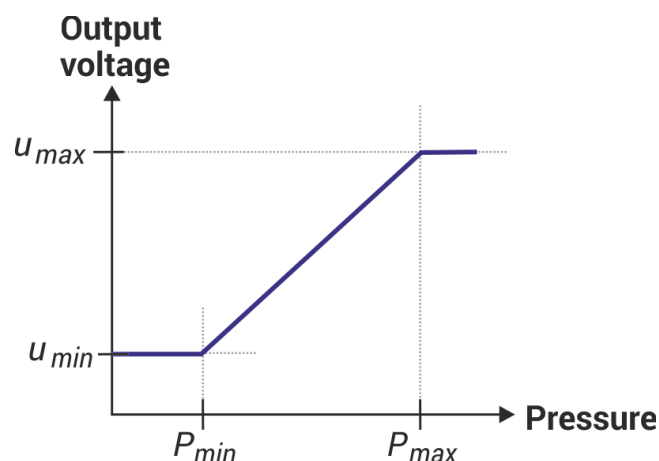

#### Configuration of output:

When programming the voltage output scaling, the minimum and maximum output voltage must be entered in millivolt and the minimum and maximum pressure in transducer configured pressure unit.

Command syntax:

AO!<Output1&2>, <LOW PRESSURE VALUE>,<HIGH PRESSURE VALUE>,<LOW VOLTAGE VALUE>,<HIGH VOLTAGE VALUE>

Example: Configure the analog 1 output linear expression between 1 VDC @ 10 mbar and 10 VDC @ 100 mbar.

Send: @254AO!1,10,1000,100,10000\

Reply: @253ACKAO  
ANALOG OUT 1  
#: PRESSURE , AOUT [mV]  
L : +1.00E+01, 1000  
H : +1.00E+02, 10000\

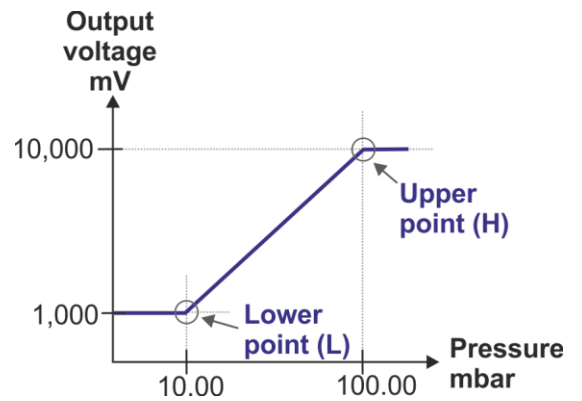

### Set Baud Rate (BAUD)

The VDM-2 supports the following baud rates: 4800, 9600, 19.000, 38.400, 57.600, 115.200. Note that whenever the baud rate is changed, the VDM-2 will send an acknowledgement to the BAUD command using the old baud rate setting before switching to the new one.

Example: Change the baud rate to 115.200:

Send: @254BAUD!115200\

Reply: @253ACK115200\

---

## Pressure Measurement (P)

The digital pressure measurement can be accessed using the S4-Connect™ programmer or RS-232/485 serial digital interface.

Reading the digital pressure value:

Send:            @254P?\

Reply:           @ACK1013.12\

## Quick Data Acquisitions (Q)

The quick data acquisition command provides all variable measurement data and setpoint status in one string.

Reading the quick data acquisition:

Send:            @254Q?\

Reply:           @ACK1.0000E-2,1.2300E-2,1.2300E-2,23.24,101

Configuration of the quick data acquisition:

Send:            @254Q!PZ,SP,TEMP\

Reply:           @ACK1.230E+2,101,23.24

Read the currently configured Q-configuration:

Send:            @254Q?CONFIG\

Reply:           @ACKPZ,SP,TEMP\

Parameters	Description
PZ	Piezo pressure measurement
TEMP	Temperature measurement
SP	Setpoint status

### Setpoint status

The setpoint status value provides a 3-digit value, where each digit represents the status of the setpoint relay 1, 2 and 3, respectively. Each digit may be 1=Energized relay, 0=De-energized relay, X=No relay installed.

## Temperature Measurement (T)

The VDM-2 has a built-in high-resolution precision temperature sensor that provides a temperature measurement of the vacuum gas in degrees Celsius with a typical accuracy of better than  $\pm 1$  °C.

Reading the temperature:

Send:            @254T?\

Reply:           @ACK25.22\

## Unit (U)

The VDM-2 can be configured to three different pressure units and three different temperature units. If no explicit parameter (pressure, temperature) is defined, pressure is assumed.

Pressure unit		
mbar	Pascal	torr

Temperature unit		
Celsius	Fahrenheit	Kelvin

Setting pressure unit to Pascal:

Send: @254U!PASCAL\

Reply: @ACKPASCAL\

Setting pressure unit to mbar:

Send: @254U!P,MBAR\

Reply: @ACKMBAR\

Setting temperature unit to Fahrenheit:

Send: @254U!T,FAHRENHEIT\

Reply: @ACKFAHRENHEIT\

Reading current temperature unit:

Send: @254U?T\

Reply: @ACKFAHRENHEIT\



**INFORMATION:** All values related to pressures like setpoint values and full-scale must be entered in the current unit for the transducer. When changing unit all setpoint values are converted to the new unit and consequently setpoint functionality will remain intact when changing unit.

## Statistics (STAT)

The statistics function logs the number of operation hours and the maximum and minimum measured pressure or temperature value. If no explicit parameter (pressure, temperature) is defined, pressure is assumed.

Reading the statistics (parameter is left out, so pressure is assumed):

Send: @254STAT?\

Reply: @254ACKSTAT<cr>  
MIN : 5.6104E+00<cr>  
MAX : 1.0159E+03<cr>  
HOURS : 37\

Reading the temperature statistics:

Send: @254STAT?T\

Reply: @254ACKSTAT<cr>  
MIN : 2.345E+01<cr>  
MAX : 3.123E+01<cr>  
HOURS : 37\

---

Clearing the statistics (parameter is left out, so pressure is assumed):

Send:           **@254STAT!CLEAR\**

Reply:          **@254ACKCLEAR\**

## Switch Function (Optional)

The solid-state setpoint relay function can be used for controlling and surveillance by external equipment.

The three independent solid-state switch relays can be used for external control of pumps, valves, safety interlock circuits and other external equipment. The basic control uses on/off regulation with a programmable setpoint and hysteresis value. Each solid-state relay offers both normally closed and normally open contacts. Solid-state relays are a hardware option that must be specified when ordering the transducer.

Compared to electro-mechanical relays, the solid-state relays offer superior reliability and faster switching time while providing arc free contacts and generating no EMI (electromagnetic interference) when switching contacts.

The relays are UL listed, CSA recognized, and EN/IEC 60950-1 certified for maximum confidence when used to control critical vacuum processes and high-cycle applications.

The relay switches are per default controlled by the pressure measurement but can also be configured to be controlled by the internal temperature sensor.



**WARNING!** Do not exceed maximum load rating of 250 mA, 50 VDC / VAC peak on relay contacts. Special precautions must be taken when driving an inductive load. Ensure that inrush peak current does not exceed relay contact ratings.

The switch can be configured to close the relay contact either above or below the setpoint value.

### Above

When the switch direction is configured to above, the relay will remain energized (NO contact closed) until the hysteresis value is exceeded. Then it will change to de-energized (NC contact closed). The relay will energize (NO contact closed) again when the setpoint value is exceeded.

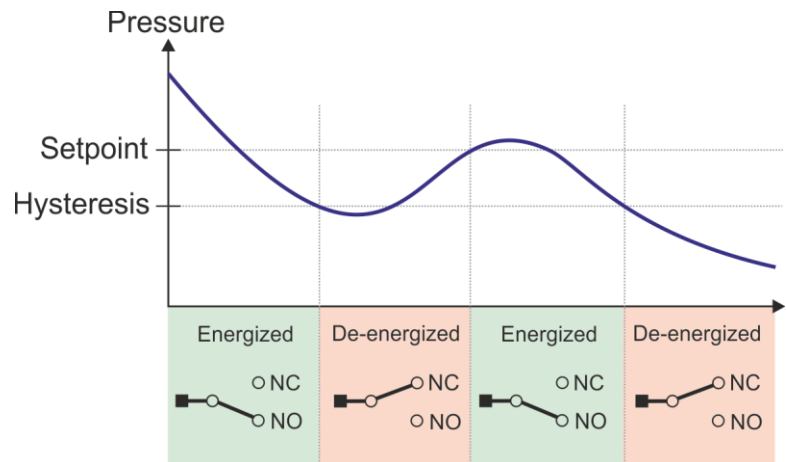

### Below

When the switch direction is configured to below, the relay will remain de-energized (NC contact closed) until the hysteresis value is exceeded. Then it will change to energized (NO contact closed). The relay will de-energize (NC contact closed) again when the setpoint value is exceeded.

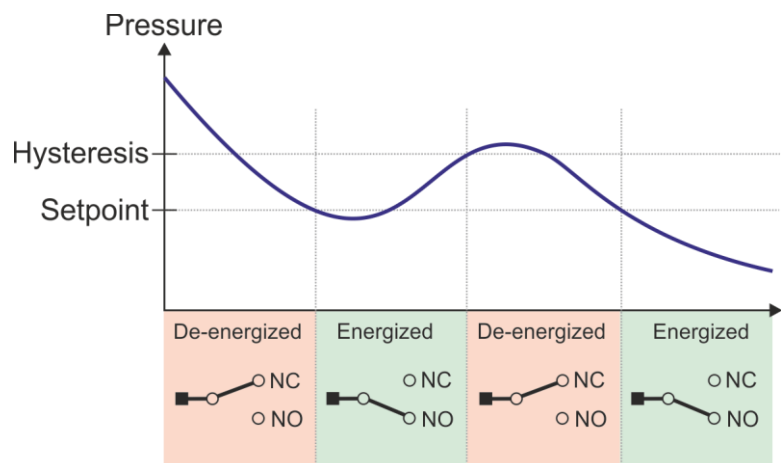

## Configuration of Setpoint

Setpoints can be configured either via the S4-Connect™ software or the command protocol.



**INFORMATION:** All values related to pressures like setpoint values and full-scale must be entered in the current unit for the transducer. When changing unit all setpoint values are converted to the new unit and consequently setpoint functionality will remain intact when changing unit.

Command sequence example:

@254SP?\ (This step is not mandatory.) Print an overview of all setpoint settings. If no setpoints have previously been defined, a VDM-2 with three relays will produce the following overview.

```
#: ENABLE, ENERGIZED, SOURCE, DIRECTION, VALUE, HYSTERESIS<cr>
1: OFF, NO, PRES, ABOVE, +0.000E+00, +0.000E+00<cr>
2: OFF, NO, PRES, ABOVE, +0.000E+00, +0.000E+00<cr>
3: OFF, NO, PRES, ABOVE, +0.000E+00, +0.000E+00<cr>
\
```

@254SPS!1,P\  
@254SPD!1,ABOVE\  
Assign pressure measurement as the source for Setpoint 1. Configure the Setpoint 1 relay to be energized whenever the pressure reading is greater than the Setpoint 1 value. Whenever this value is changed, the corresponding Hysteresis value is automatically calculated to either -10% of the current setpoint value (when direction = ABOVE) or +10% of the current setpoint value (when direction = BELOW). If the temperature measurement is selected as the source, the automatically calculated Hysteresis values will be -1°C /+1°C instead of -10%/+10%.

@254SPV!1,600\  
Set the value of Setpoint 1 to 600 and auto-calculate Hysteresis value. As the direction is set to ABOVE, the hysteresis value will be automatically set to 540 (the setpoint value -10%). Had the direction been BELOW, the hysteresis would have been automatically set to 660 (the setpoint value +10%).

@254SPH!1,500\  
@254SPE!1,ON\  
@254SPR?1\  
Set the Hysteresis value for Setpoint 1 to 500. Enable Setpoint 1. Get the current status of the Setpoint 1 relay.

@254SP?\ (This step is not mandatory.) Print an overview of all setpoint settings to verify the new settings. If the unit is set to mbar and the pressure reading is above 600 – energizing the Setpoint 1 relay – the generated output would look like this:

```
#: ENABLE, ENERGIZED, SOURCE, DIRECTION, VALUE, HYSTERESIS<cr>
1: ON, YES, PRES, ABOVE, +6.000E+00, +5.000E+00<cr>
2: OFF, NO, PRES, ABOVE, +0.000E+00, +0.000E+00<cr>
3: OFF, NO, PRES, ABOVE, +0.000E+00, +0.000E+00<cr>
\
```

Command	Description	Valid input
SPD	Setpoint Direction	<SETPOINT #>, <ABOVE, BELOW>
SPE	Setpoint Enable	<SETPOINT #>, <OFF/ON>
SPH	Setpoint Hysteresis	<SETPOINT #>, <PRESSURE VALUE>
SPV	Setpoint Value	<SETPOINT #>, <PRESSURE VALUE>
SPS	Setpoint Source (pressure or temperature)	<SETPOINT #>, <P/T>
SP	Read all setpoint settings	-

## Configuration of setpoint using VDM-2 configuration software

The screenshot displays the VDM-2 configuration software interface. On the left, a large digital display shows the 'Current Reading' as 1015,38 mbar. Below it is a line graph showing pressure fluctuations over time. On the right, the 'Advanced' configuration tab is active, showing 'Setpoint Status' as OFF, 'Direction' set to 'Trigger On Rising Temperature ("ABOVE")', and 'Source' as 'Pressure sensor'. The 'Setpoint' is configured to 60 mbar and 'Hysteresis' to 50 mbar. An 'Apply Settings' button is visible. A smaller graph on the right illustrates the setpoint and hysteresis levels on a pressure vs. time axis.

Temperature Transmitter  
Model: PCM-1-10121111  
S/N: 12345678910A

### Pre-configuration of Setpoint values

The VDM-2 transducer can be delivered with custom defined setpoint values. Contact Sens4 sales team for more information.

---

## Product Information and Identification

The VDM-2 has a serial number, product part number, manufacturer identity and firmware version programmed in its internal non-volatile memory.

### Serial number:

Send: @254SN?\n  
Reply: @ACK191230123456;

### Part number:

Send: @254PN?\n  
Reply: @ACKVDM-2-123456;

### Manufacturer identity:

Send: @254MF?\n  
Reply: @ACKSENS4;

### Firmware version:

Send: @254FV?\n  
Reply: @ACK1.00;

## Maintenance

Maintenance is not required in many applications during the lifecycle of this product. The calibration may shift during the life-time and re-calibration by adjusting the zero point and full-scale value can be performed by the user.

The VDM-2 can be user configured, calibrated and tested using the S4-Connect™ USB adapter or RS-232/485 interface.

### Adjustment of the Zero Offset Point

The VDM-2 has an active and individual temperature compensation to account for zero-point drift. In many applications, a user adjustment of the zero point is not required during the lifetime of the product.



**INFORMATION:** The VDM-2 should be zero adjusted after first time installation. Measurement zero offset can shift during transportation or if the mounting orientation of the transducer is changed.

If drift of the zero-point is observed, it can be adjusted using the S4-Connect™ USB programmer, RS-232 / RS-485 communication interface or by pressing the zero switch.

#### Zero-point adjustment procedure using digital interface

1. Evacuate the transducer to a vacuum pressure below 1.00E-2 mbar.
2. Send command: @254VAC!\n
3. Reply: @254ACK<value>\n

The reply <value> is the calculated offset pressure value as function of the factory default zero offset subtracted from the user offset adjustment.

If the recommended zero adjustment vacuum pressure cannot be achieved due to inadequate vacuum pumping capacity, the zero-point adjustment can be performed at a higher pressure by entering the actual pressure value measured by a reference transducer. Following command example will perform a zero adjustment at 5.00E-5 mbar:

1. Adjust the vacuum pressure to a known value
2. Send command: @254VAC!5.00E-5\n
3. Reply: @254ACK<value>\n

---

### Zero-point adjustment procedure using the zero switch

The VDM-2 can also be zero adjusted by pressing the zero adjustment switch using a tool with a maximum diameter of 1.5 mm.



1. Evacuate the transducer to a vacuum pressure below 1.00E-2 mbar.
2. Press the zero switch for 2 seconds
3. The LED will strobe green after completion of zero adjustment or red if the transducer is not able to perform zero adjustment.

### Adjustment of Full-scale

#### Full-scale Adjustment

The piezo sensor can be full-scale adjusted using the digital interface by the following procedure:

1. Expose the transducer flange to atmospheric ambient pressure
2. Obtain the actual atmospheric pressure (e.g. 1,013.1 mbar) from a reference gauge
3. Send the command: `@254FS!PZ,1013.1\`
3. Reply: `@254ACK<value>\`

The acknowledge value represents the scaling factor for the new piezo full-scale calibration. The full-scale adjustment can be executed in the pressure range 400-1,100 mbar (300-825 Torr).

## Resetting to factory default

The Factory Default command will reset all user settings to factory default, including setpoint settings, pressure unit and user-adjustment of zero point and full-scale.

Sens4 offers pre-configuration of user parameters, and if the product is delivered with a special user configuration, the factory default command will reset to the original user configuration as delivered.

Reset to factory default:

Send:            **@254FD!\**

Reply:           **@ACKFD\**

Parameter	Value
Vacuum zero adjustment	0
Full scale adjustment	1
Unit	As delivered
Baud rate	9600
Address	253
Analog output configuration	As delivered
Setpoint direction	Above or as delivered
Setpoint enable	OFF or as delivered
Setpoint hysteresis	As delivered
Setpoint value	As delivered
Setpoint source	Pressure

## Individual reset to factory default

It is possible to reset only certain settings to their factory default values. This is done by adding an optional argument to the FD command. If the argument is left blank, all parameters will be reset to their default values.

Send:            **@254FD!<ARGUMENT>\**

Reply:           **@ACKFD\**

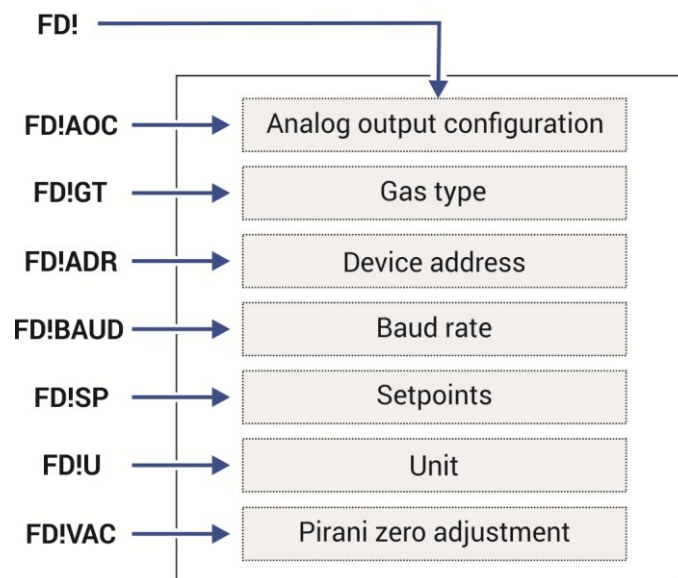

## Reset to factory default using S4-Connect™ software

Go to the factory Def. tab and check the parameters to be reset and press the “Issue Factory Default” button.

The screenshot displays the S4-Connect software interface for a pressure transmitter. The main display shows a current reading of 1015,38 mbar. Below this is a line graph titled 'Pressure [mbar]' vs 'Time []' showing a decreasing trend from approximately 1015,75 mbar at time 462 to 1015,25 mbar at time 512. The right-hand side features a configuration menu with tabs for 'Analog Output', 'Relay', 'Factory Def.', and 'Advanced'. The 'Factory Def.' tab is active, showing a 'Select Items' list with checkboxes for 'All', 'Analog Output Scaling', 'Damping', 'Unit', 'Setpoint', 'Full-scale', and 'Zero Point'. The 'Unit' and 'Setpoint' options are checked. An 'Issue Factory Default' button is located at the bottom of this menu. At the bottom of the interface, the device is identified as a 'Temperature Transmitter' with model PCM-1-10121111 and serial number 12345678910A. A small image of the transmitter and its cable is shown next to the text. The SENS4 logo is in the bottom right corner.

Current Reading: 1015,38 mbar

Pressure [mbar] vs Time [] graph showing a decreasing trend.

Configuration Tab: **Factory Def.**

Select Items:

- All
- Analog Output Scaling
- Damping
- Unit
- Setpoint
- Full-scale
- Zero Point

**Issue Factory Default**

Temperature Transmitter  
Model: PCM-1-10121111  
S/N: 12345678910A

SENS4



---

## Return

Before returning a product to Sens4 proper return forms and a return materials authorization (RMA) must be filled out. The RMA procedure can be found on: [www.sens4.com/support](http://www.sens4.com/support)



**INFORMATION:** Sens4 does not accept return of products without return materials authorization. Sens4 does not accept any return of products that have been exposed to or contaminated with radioactive, chemical, biological or other harmful or dangerous substances.

# RMA – Return Material Authorization

This form should be filled out and enclosed with the package  
Please contact Sens4 to obtain RMA # email: [support@sens4.com](mailto:support@sens4.com)



Sens4 A/S  
Ndr. Strandvej 119G  
3150 Hellebaek  
Denmark

RMA#: \_\_\_\_\_ Date: \_\_\_\_\_

Company name \_\_\_\_\_

Address: \_\_\_\_\_

\_\_\_\_\_  
\_\_\_\_\_  
\_\_\_\_\_

Contact name: \_\_\_\_\_

Phone: \_\_\_\_\_

Email: \_\_\_\_\_

Part number: \_\_\_\_\_ Serial number: \_\_\_\_\_

## Reason for the return:

Warranty Repair	Chargeable Repair	Exchange	Loan	Demo	Other	<i>If other, please list:</i>
<input type="checkbox"/>	<input type="checkbox"/>	<input type="checkbox"/>	<input type="checkbox"/>	<input type="checkbox"/>	<input type="checkbox"/>	_____

## Has the product been contaminated with or exposed to the following?

	No	Yes	
Biological hazard	<input type="checkbox"/>	<input type="checkbox"/>	<i>If other, please list:</i> _____
Radioactivity	<input type="checkbox"/>	<input type="checkbox"/>	
Toxic gases or materials	<input type="checkbox"/>	<input type="checkbox"/>	
Other harmful substances	<input type="checkbox"/>	<input type="checkbox"/>	



If "yes" has been answered to any of the above questions please note that **Sens4 does not accept any return of products that have been exposed to or contaminated with radioactive, chemical, biological and other harmful or dangerous substances.**

For questions regarding our return policy please contact email: [support@sens4.com](mailto:support@sens4.com)

## If the product is being returned for service repair, please describe failure mode and application:

Application: \_\_\_\_\_

Failure mode: \_\_\_\_\_

\_\_\_\_\_  
\_\_\_\_\_  
\_\_\_\_\_

I, the undersigned, hereby acknowledge that the information provided on this form is legally binding and declare that the information supplied is accurate and adequate to judge any harmful contamination.

\_\_\_\_\_  
Date Name Signature

## Specifications

<b>Specifications</b> <small>Specifications</small>	
Measuring range in mbar	0.1 to 1333 mbar (0.1 to 1000 Torr)
Measuring principle	Ceramic diaphragm piezo resistive
Accuracy 100 to 1333 mbar	0.5% of reading
Accuracy 1 to 99.9 mbar	0.05% of full scale (1333 mbar)
Hysteresis $1 \times 10^{-1}$ to 10 mbar (ISO19685:2017)	1% of reading
Hysteresis 10 to 1200 mbar (ISO19685:2017)	0.1% of reading
Analog output resolution	16 bit (150 $\mu$ V)
Analog output update rate	560 Hz
Response time (ISO 19685:2017)	<20 ms
Temperature compensation	+10 to +50 °C
Solid state relay set point range	1 to 1333 mbar (0.75 to 1000 Torr)
Solid state relay contact rating	50 V, 100 mA <sub>rms</sub> / mA <sub>DC</sub>
Solid state relay contact endurance	Unlimited (no mechanical wear)
Solid state relay approvals	UL Recognized: File E76270 CSA Certified: Certificate 1175739 EN/IEC 60950-1 Certified
<b>Environment conditions</b> <small>Environment conditions</small>	
Operating ambient temperature	-20 to +50 °C
Media temperature	-20 to +50 °C
Storage ambient temperature	-40 to +80 °C
Bake-out temperature (non-operating)	+80 °C
Maximum media pressure <sup>(3)</sup>	2 bar absolute (29 psia)
Burst pressure <sup>(4)</sup>	4 bar absolute (58 psia)
Mounting position	Arbitrary
Protection rating, EN 60529/A2:2013	IP40
Humidity, IEC 68-2-38	98%, non-condensing
<b>Power supply</b> <small>Power supply</small>	
Supply voltage	12-30 VDC
Power consumption	240 mW (max)
Reverse polarity protection	Yes
Overvoltage protection	Yes
Internal fuse	100 mA (thermal; recoverable)
<b>Materials</b> <small>Materials</small>	
Enclosure	SS 1.4307 / AISI 304L / Aluminum 6061
Vacuum Process flange (media wetted)	SS 1.4401 / AISI 316
Vacuum exposed materials (media wetted) Standard version	316 Stainless steel, Viton®, Aluminum oxide (Al <sub>2</sub> O <sub>3</sub> 96%)
Vacuum exposed materials (media wetted) Parylene protected version	316 Stainless steel, Viton®, Parylene
Process leak tightness	<1·10 <sup>-9</sup> mbar·l/s
<b>Approvals</b> <small>Approvals</small>	
CE	EMC directive 2014/30/EU
RoHS compliance	Directive EU 2015/863

- (1) Accuracy specifications are typical values at stable temperature after zero adjustment.
- (2) Viton® is a trademark of THE CHEMOURS COMPANY FC, LLC
- (3) Overpressure limit is the maximum allowed pressure without irrevocable damage to the sensor element.
- (4) Burst pressure is the maximum pressure without rupture of sensor diaphragm.

Specifications are subject to change without further notice.

## Dimensions

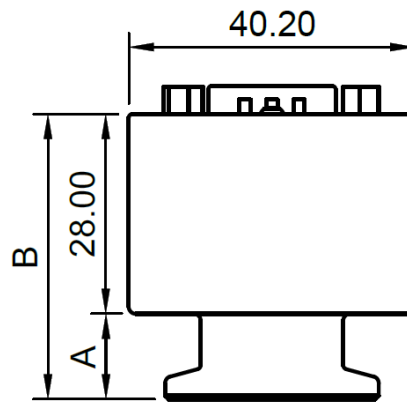

Flange type	A [mm]	B [mm]	A [inch.]	B [inch.]
DN16KF (P/N: VDM-2-1...)	12.00	40.00	0.47	1.57
DN25KF (P/N: VDM-2-2...)	12.00	40.00	0.47	1.57
VCR4 <sup>1</sup> (P/N: VDM-2-4...)	33.70	61.70	1.32	2.43
VCR8 <sup>1</sup> (P/N: VDM-2-5...)	29.43	57.43	1.15	2.26
1/8" NPT (P/N: VDM-2-3...)	37.00	65.00	1.45	2.56
DN16CF (P/N: VDM-2-6...)	21.83	49.83	0.86	1.96



## Accessories

### S4-Connect™

USB programmer for transmitters and transducers



Part number	Description
PRG-S4-15DS-01	S4-Connect programmer USB, 15p HD D-sub connector
PRG-S4-9DS-01	S4-Connect programmer USB, 9p D-sub connector
PRG-S4-RJ45-01	S4-Connect programmer USB, 8p FCC68/RJ45
PRG-S4-HM-01	S4-Connect programmer USB, 6p Hirschmann

### RS232 / RS485 interface

USB-to-Serial converter for VDM-2 transducers

Part number	Description
PRG-RS2-15DS-01	RS232 communicator USB, 15p HD D-sub connector
PRG-RS4-15DS-01	RS485 communicator USB, 15p HD D-sub connector
PRG-RS2-9DS-01	RS232 communicator USB, 9p D-sub connector
PRG-RS4-9DS-01	RS485 communicator USB, 9p D-sub connector

### Cables

Part number	Description
CAB-F15DSM15DS-003	15 p HD D-sub female to 15 p D-sub male with 3 m cable
CAB-F15DSM15DS-005	15 p HD D-sub female to 15 p D-sub male with 5 m cable
CAB-F15DSM15DS-010	15 p HD D-sub female to 15 p D-sub male with 10 m cable
CAB-F15DSM15DS-003	9 p D-sub female to 15 p D-sub male with 3 m cable
CAB-F15DSM15DS-005	9 p D-sub female to 15 p D-sub male with 5 m cable
CAB-F15DSM15DS-010	9 p D-sub female to 15 p D-sub male with 10 m cable

---

## Declaration of Conformity

This declaration of conformity has been made in accordance with EN ISO/IEC 17050-1:2010

Manufacturer: Sens4 A/S  
Address: Nordre Strandvej 119G  
3150 Hellebaek  
Denmark

We hereby declare under our sole responsibility that the following products:

Product description: Pressure Transducer  
Product part number: VDM-2-xxxxxxx

Complies with the requirements of following relevant European Union harmonization directive:

Electromagnetic Compatibility (EMC) Directive 2014/30/EU  
RoHS 3 Directive EU 2015/863

Conformity is assessed in accordance to the following standards:

Reference: Date	Title
EN 61326-1:2021	Product family standard, Measurement, control and laboratory equipment
EN 61326-2-3:2021	Test configuration, operational conditions and performance criteria for transducers with integrated or remote signal conditioning
EN 61000-3-2:2006 + A1:2009 and A2:2009	Limits for harmonic current emissions
EN 61000-3-3:2008	Limitation of voltage changes, voltage fluctuations and flicker in public low-voltage supply systems
EN 63000:2018	Technical documentation for the assessment of electrical and electronic products with respect to the restriction of hazardous substances

Signed on behalf of: Sens4 A/S  
Place of issue: Hellebaek, Denmark  
Date of issue: May 16<sup>th</sup>, 2025  
Signature:



Name, Title 

---

Ole Wenzel, Chief Executive Officer

Document number: DOC-VDM-2-01, Revision: B

## Contact and support

This product has been engineered and made in Denmark by:

Sens4 A/S  
Nordre Strandvej 119G  
3150 Hellebaek  
Denmark

Phone: +45 88447044  
Email: [info@sens4.com](mailto:info@sens4.com)

Website: [www.sens4.com](http://www.sens4.com)

## Other featured Products from Sens4

The Sens4 vacuum transducer product range offers the market's most advanced multi-sensor transducers for use in a wide selection of industrial and scientific vacuum applications.



### TrueVac™ Controller

The TrueVAC™ Vacuum Controller is an advanced, versatile instrument designed for precise monitoring and control of vacuum systems across a wide range of industrial and scientific applications. With its high-resolution digital display and intuitive interface, TrueVAC offers real-time vacuum measurement and control, allowing users to efficiently manage processes and maintain optimal conditions.

### VPM-15 TriCAP™ Transducer

The VPM-15 TriCAP™ transducer is pin and output compatible with the VDM-2. The VPM-15 has an additional CDG (Capacitance Diaphragm Gauge) sensor to provide the gas independent measuring from 5.0E-3 to 1333 mbar that can be an advantage in applications where gas composition or type can change.

For demanding applications, the VPM-15 TriCAP™ is available with corrosion resistant ceramic or Parylene coated sensors.



### VPM-7 for Load-lock Control

The VPM-7 SmartPirani™ ATM is designed for load-lock pressure control and enable accurate control of vacuum system venting. It provides flexible interface and several control options including high-resolution analog output with emulation curves for other vendors vacuum gauges, 3 independent solid-state relays and digital RS-232 or RS-485 interface.

For more information visit:

[www.sens4.com](http://www.sens4.com)



Our passion | Your value™